

PLAIN CEMENT CONCRETE CURB

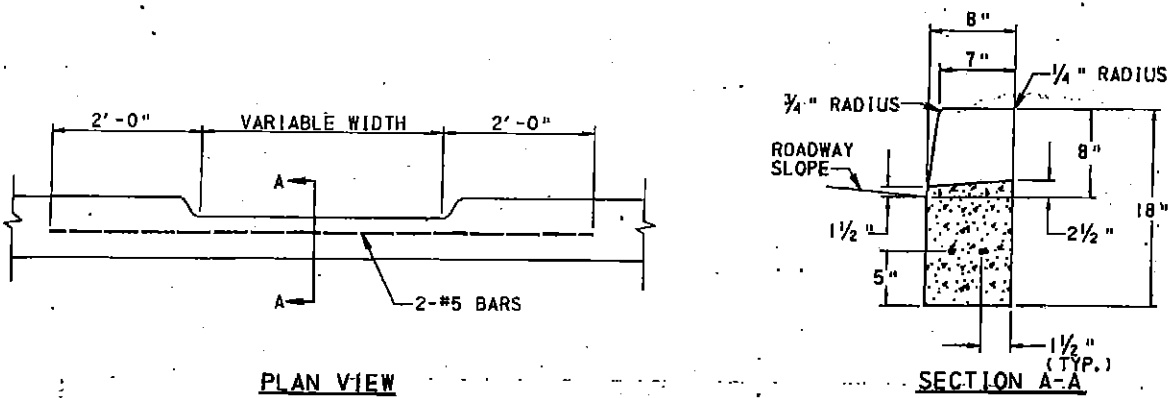

DEPRESSED CURB FOR DRIVES

SECTION 630 — PLAIN CEMENT CONCRETE CURB

630.1 DESCRIPTION — This work is construction of plain cement concrete curb.

630.2 MATERIAL —

- Class A Cement Concrete — Section 704
- Class A Cement Concrete (Slip Forming) — Section 704, except with a maximum slump of 1½ inches.
- Premolded Expansion Joint Filler — Section 705.1
- Curing and Protecting Covers — Section 711.1
- Concrete Curing Compound — Section 711.2(a)
- Mortar — Section 1001.2(d)
- Joint Sealing Material — Section 705.4(b) or (c)

630.3 CONSTRUCTION — As shown on the Standard Drawings, as specified in the applicable parts of Section 1001.3, and as follows:

- (a) **Excavation.** Excavate to the required depth, then compact the material upon which the curb is to be constructed to a firm, even surface.
- (b) **Forms.** Use acceptable metal forms, except on sharp curves and short tangent sections, where wood forms may be used. Use forms which will not discolor the concrete.
- (c) **Placing and Finishing Concrete.** Place the concrete in the forms in layers not exceeding 5 inches in depth when spading, or layers not exceeding 15 inches in depth when using a vibrator to eliminate voids. Provide drainage openings through the curb, at the elevation and of the size required, where indicated or directed. Smoothly and evenly finish the top surface of the curb, using a wood float. While the concrete is still plastic, round the edges of the face and back of the curb. Place depressed curbs for drives or curb cut ramps, where indicated or directed.
- (d) **Curb Machine.** The concrete curb may be placed with an acceptable, self-propelled machine. Uniformly feed the concrete to the machine so the concrete maintains the shape of the section, without slumping after extrusion. Voids or honeycomb on the surface of the finished curb will not be allowed. Immediately after extrusion, perform any additional surface finishing required.
- (e) **Joints.** Form or saw contraction joints ¾-inch wide and 2 inches deep. Saw as soon as possible after the concrete has set sufficiently to preclude raveling

during the sawing and before any shrinkage cracking occurs in the concrete. The depth of saw cut may be decreased at the edge adjacent to the pavement to obtain a maximum depth without pavement damage.

Tool the edges of construction joints to a ¼-inch radius.

Place ¾-inch premolded expansion joint material, cut to the cross sectional area of the curb, at structures, and at the end of the work day.

Seal joints, as specified in Section 501.3(n).

(f) **Removal of Forms.** Do not remove forms until such time it will not be detrimental to the concrete. Correct irregular surfaces by rubbing with a carborundum stone. Brush finishing or plastering will not be permitted. Fill minor defects with mortar.

(g) **Backfilling and Embankment.** As soon as possible after the removal of forms, backfill the voids in front and back of the curb, using acceptable embankment material, as specified in Section 206.3(b)4.

Complete embankments in back of raised curbs, as indicated, and as specified in Section 206.3, except carefully compact the embankment by means of mechanical tampers, or rollers, if permitted, not exceeding 8 tons. Dispose of unsuitable and surplus material.

630.4 MEASUREMENT AND PAYMENT — Linear Foot

Depressed curb will be measured and paid for as full depth curb of the type indicated.

SECTION 676 — CEMENT CONCRETE SIDEWALKS

676.1 DESCRIPTION — This work is construction of cement concrete sidewalks on an aggregate bed.

676.2 MATERIAL —

- Class A Cement Concrete —Section 704
- Aggregate —Section 350.2
- Premolded Expansion Joint Filler —Section 705.1
- Concrete Curing Compound —Section 711.2(a)
- Curing and Protecting Covers —Section 711.1

676.3 CONSTRUCTION —

(a) **Preparation of Foundation.** Excavate, as required, and form the foundation at a depth 10 inches below and parallel with the finished surface of the sidewalk. When directed, remove unsuitable material in accordance with Section 203.1(b). Thoroughly compact the foundation, finish to a firm, even surface; moisten if required.

(b) **Placing Aggregate for Bed.** Spread aggregate on the prepared foundation to form a thoroughly compacted bed 6 inches deep.

(c) **Forms.** Use acceptable wood or metal forms extending the full depth of concrete.

(d) **Concrete.** As specified in the applicable parts of Section 1001.3.

Place concrete 4 inches deep. Strike off, finish, and test, as specified in Section 501.3(f) and (g), except that manual operations are allowed and a light broom finish applied.

Form outside edges and joints with a 1/4-inch radius edging tool.

Form transverse dummy joints at 5-foot intervals, approximately 1/8-inch wide and at least 1 inch deep.

(e) **Expansion Joints.** Place 1/2-inch premolded, expansion joint material for the full depth of the sidewalk, opposite expansion joints in adjacent curb, between the sidewalk and curb, and between the sidewalk and rigid structures.

(f) **Removal of Forms.** Do not remove side forms until at least 12 hours after placing concrete. After removal of forms, fill minor honeycombed areas with mortar. As directed, remove and replace defective major honeycombed areas.

(g) **Backfilling.** After the concrete has cured for at least 72 hours, backfill spaces adjacent to the sidewalk, using acceptable embankment material, as specified in Section 206.3(b)4.

676.4 MEASUREMENT AND PAYMENT —

- (a) Cement Concrete Sidewalks. Square Yard
- (b) Class 1A Excavation. Cubic Yard

§505. Sidewalks and Curbs.

1. Sidewalks.

A. Where Required. Sidewalks shall be provided along all streets except where, in the opinion of the Board, they are unnecessary for the public safety and convenience.

B. Width and Thickness. Sidewalks shall not be less than four (4') feet in width in residential areas. A greater width may be required in areas in which apartments or business buildings are located or as deemed necessary at the discretion of the Board.

C. Sidewalks shall be located between the curb and right-of-way line three (3') feet from the curblines. The grade and paving of the sidewalks shall be continuous across driveway, except in certain cases where heavy traffic volume dictates special treatment.

D. Construction Methods.

(1) Sidewalks shall be constructed so as to discharge drainage to the street, the grade of which shall not be less than one-fourth inch (1/4") per foot.

(2) Sidewalks shall be constructed of concrete to a width as indicated for the various classifications of the street.

(3) Concrete used in sidewalk work shall be three thousand (3,000) pounds per square inch at twenty-eight (28) days with certification of the mix furnished to the Township Engineer. Concrete shall be placed in forms that are straight and securely braced. Care shall be taken to control the water content to prevent a separation of the aggregates. The concrete shall have a broom finish, and the edges shall be finished with an approved edging tool.

(4) All concrete sidewalks shall be constructed on a four-inch (4") crushed-stone or gravel base to ensure proper drainage. The concrete shall be placed so that there is a separate joint every five feet (5') and shall be so constructed that the five-foot (5') sections are completely separated from adjacent sections. One half inch (1/2") premolded expansion joints shall be placed every twenty (20') feet and between all points where the concrete sidewalk abuts a concrete curb.

(5) All concrete sidewalks shall have a minimum thickness of four inches (4"), except under driveways, where they shall have a minimum thickness of six inches (6"). The concrete apron in the driveway area shall be reinforced with wire six by six inches (6" X 6"), No. 9 wire (minimum).

(6) Where a sidewalk does not parallel a street, it may be constructed of materials other than concrete, such as a pozzolan base with a bituminous wearing surface, a bituminous base with a bituminous wearing surface, flagstone or any similar type of material; provided, however, that specifications for such materials must be submitted to the Engineer for his review and be subject to his approval.

2. Curbs.

A. Concrete curbs shall be installed along each side of every residential, secondary or commercial street or road. Concrete curbs shall be eighteen inches (18") deep, seven inches (7") wide at the top and eight inches (8") wide at the base. The nominal distance from the top of the curb to the flow line of the gutter shall be eight inches (8") on secondary, commercial, primary and residential streets. Curbing shall be built in ten-foot (10') lengths, and an approved expansion joint of one-fourth inch (1/4") minimum thickness shall be used at each joint. A combination curb and gutter may be used at the option of the developer when approved by the Township Engineer. Where combination curb and gutter is used, it must be placed on a minimum of four inches (4") of crushed stone or gravel to provide adequate drainage beneath the curb.

B. All concrete used in the construction of improvements shall be certified to develop a comprehensive stress of at least three thousand (3,000) pounds per square inch at twenty-eight (28) days with certification of the mix furnished to the Township Engineer.

C. Concrete shall be placed in forms that are straight and securely braced. Care shall be taken to control the water content to prevent separation of the aggregates. All concrete shall be thoroughly tamped into the forms. After the concrete has set sufficiently, the form shall be removed and the exposed surface shall be rubbed to provide an even finish. All edges shall be finished with an approved edging tool. To provide for driveways, depressions in the curbing may be constructed and finished during the time of pouring.

(Ord. 512, 3/26/1990, §14-5.5)

Section 3

Chapter 22, Part 8, Section 504(1)(A) is hereby amended to read as follows:

(A) Paving.

(1) All driveways for single family units must use the following minimum standards:

(a) A modified stone base course shall be installed to a compacted depth of six (6) inches.

(b) A bituminous binder course (ID-2) shall be installed to a compacted depth of one (1) inch.

(c) A bituminous wearing course (ID-2) shall be installed to a compacted depth of one (1) inch.

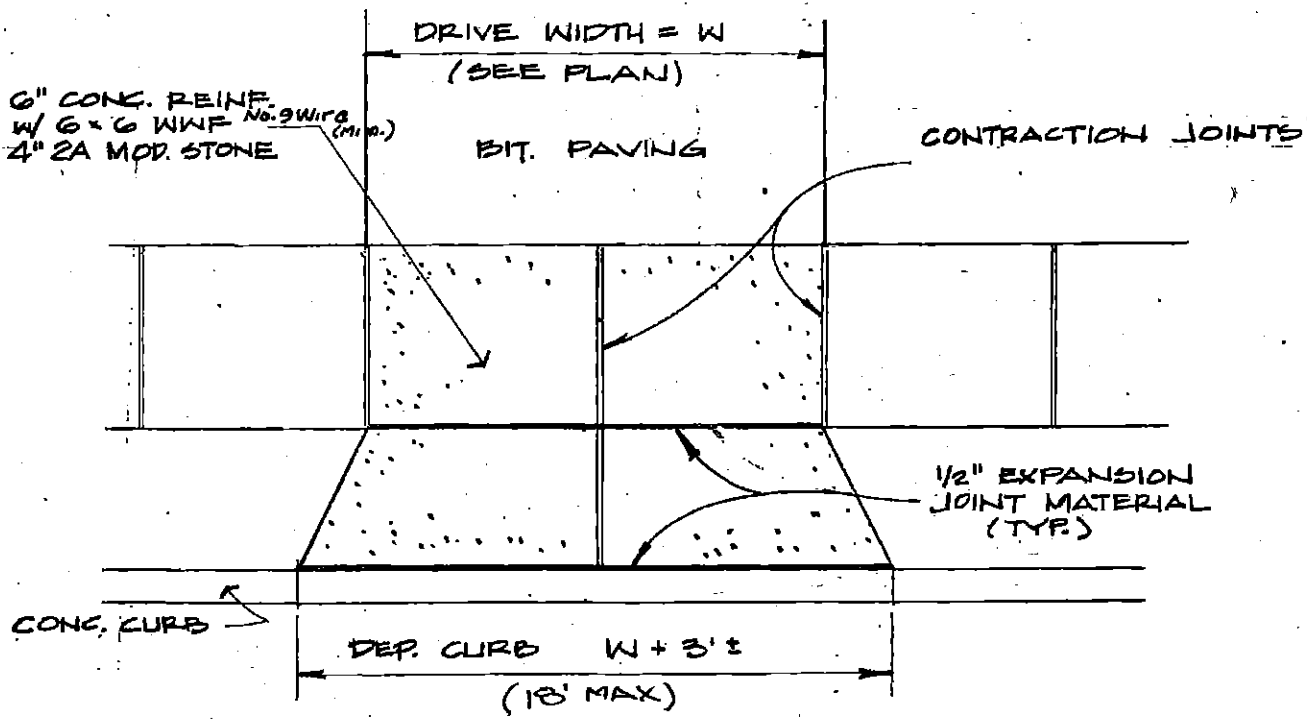

CONCRETE DRIVEWAY APRON

N.T.S.