

G. **ATTACHING TO EXISTING STRUCTURE** – Indicate method of attachment of items B through F above of the proposed structure to the existing structure, if applicable.

ADDITIONAL INFORMATION

FEES – Permit fees must be submitted with the permit application. If paying by check, please make check payable to “West Norriton Township”.

REVIEW – The application will be reviewed by the Code Enforcement and Zoning Departments for compliance with all Township codes and ordinances.

PERMIT GRANTED – **If approved, the permit will be processed and issued to you within fifteen (15) business days. Work may not start until a permit has been approved and granted.** The permit cards are to be displayed so as to be visible from the street.

PLUMBING AND ELECTRICAL – All plumbing and electrical contractors and/or their personnel must be registered and provide a Certificate of Insurance verifying Worker’s Compensation coverage, and Federal or State Employer Identification Number (EIN). In addition, each contractor must obtain the appropriate permits for the work to be done. All electrical work must be inspected by United Inspection Agency.

INSPECTIONS – Call the Township office (610-631-0450) at least 24 hours in advance to schedule each inspection. Responsibility for notification for inspections at the various stages of construction lies with the applicant and/or contractor. If the appropriate inspections are not requested, uninspected work will not be granted final approval. **If an inspection fails twice for the same code violation, a reinspection fee will be required prior to a third inspection.**

West Norriton Township

Application for Deck/Patio Plan Examination and Permit

I - LOCATION OF PROPERTY

Address: _____ City: _____

Parcel #: 63-00 _____ Lot: _____ Block: _____

II - OWNERSHIP

Private Public Tenant Other _____

III - IDENTIFICATION – To be completed by all applicants

APPLICANT Name: _____ Phone: _____

Company: _____

Address: _____

City: _____ State: _____ Zip Code: _____

Email Address: _____

OWNER Name: _____ Phone: _____

Address: _____

City: _____ State: _____ Zip Code: _____

CONTRACTOR Company: _____ Phone: _____

Name: _____

Address: _____

City: _____ State: _____ Zip Code: _____

State License Number: _____ Expiration Date: _____

DESIGN Name: _____ Phone: _____

PROFESSIONAL

Address: _____

City: _____ State: _____ Zip Code: _____

IV - TYPE OF CONSTRUCTION OR IMPROVEMENTS

Deck Patio Retaining Wall Square Footage of Construction Area _____
 New Alteration/Renovation Repair or Replacement

V - COST

Cost of Construction Improvements \$ _____

VI - FEES \$ _____

VII - SIGNATURE

Deposit of Check Representing the Fee for this Application does not Constitute Approval of or Granting of Same by West Norriton Township. I hereby certify that the proposed work is authorized by the owner of record and that I have been authorized by the owner to make this application as his agent and we agree to conform to all applicable laws of West Norriton Township.

SIGNATURE OF APPLICANT (Print & Sign)

DATE

VIII - SITE OR PLOT PLAN – See Sample Plot Plan (last page of instructions).

SCHEDULE OF FEES

DECKS AND PATIO FEES:	\$ 85.00
RETAINING WALL FEE:	\$ 35.00
ADMINISTRATION FEE:	\$ 64.00

Note: All enclosed decks and patios require a home improvement building permit.

SAMPLE DECK FLOOR PLAN

LIST ALL DIMENSIONS IN FEET & INCHES

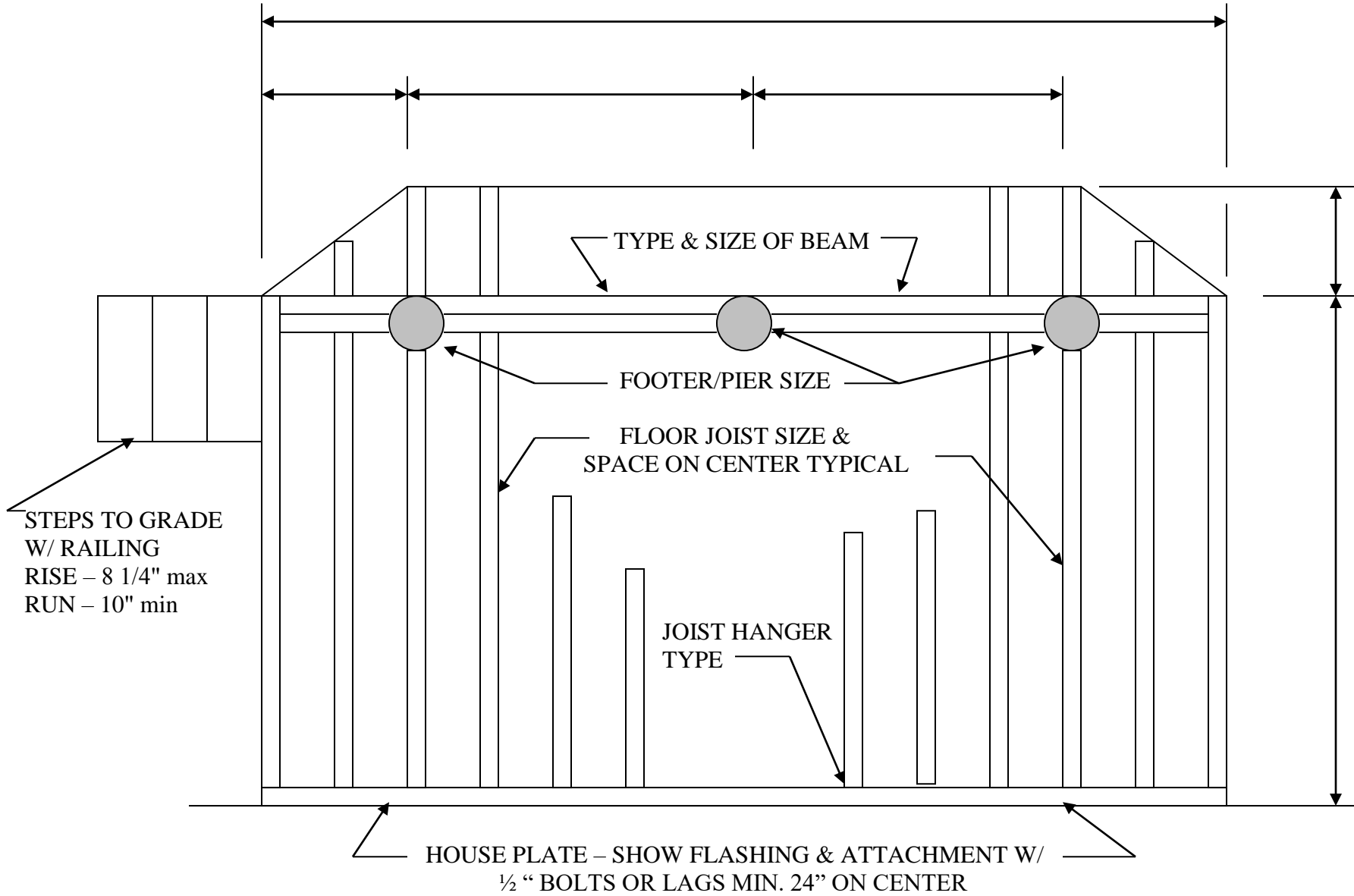

NOTE: THIS DETAIL DRAWING IS A **SAMPLE** ONLY. IT IS TO HELP IN SUMMITTING YOUR DESIGN DETAILS AND THE INFORMATION THAT IS REQUIRED FOR CODE REVIEW.

SAMPLE DECK DETAILS

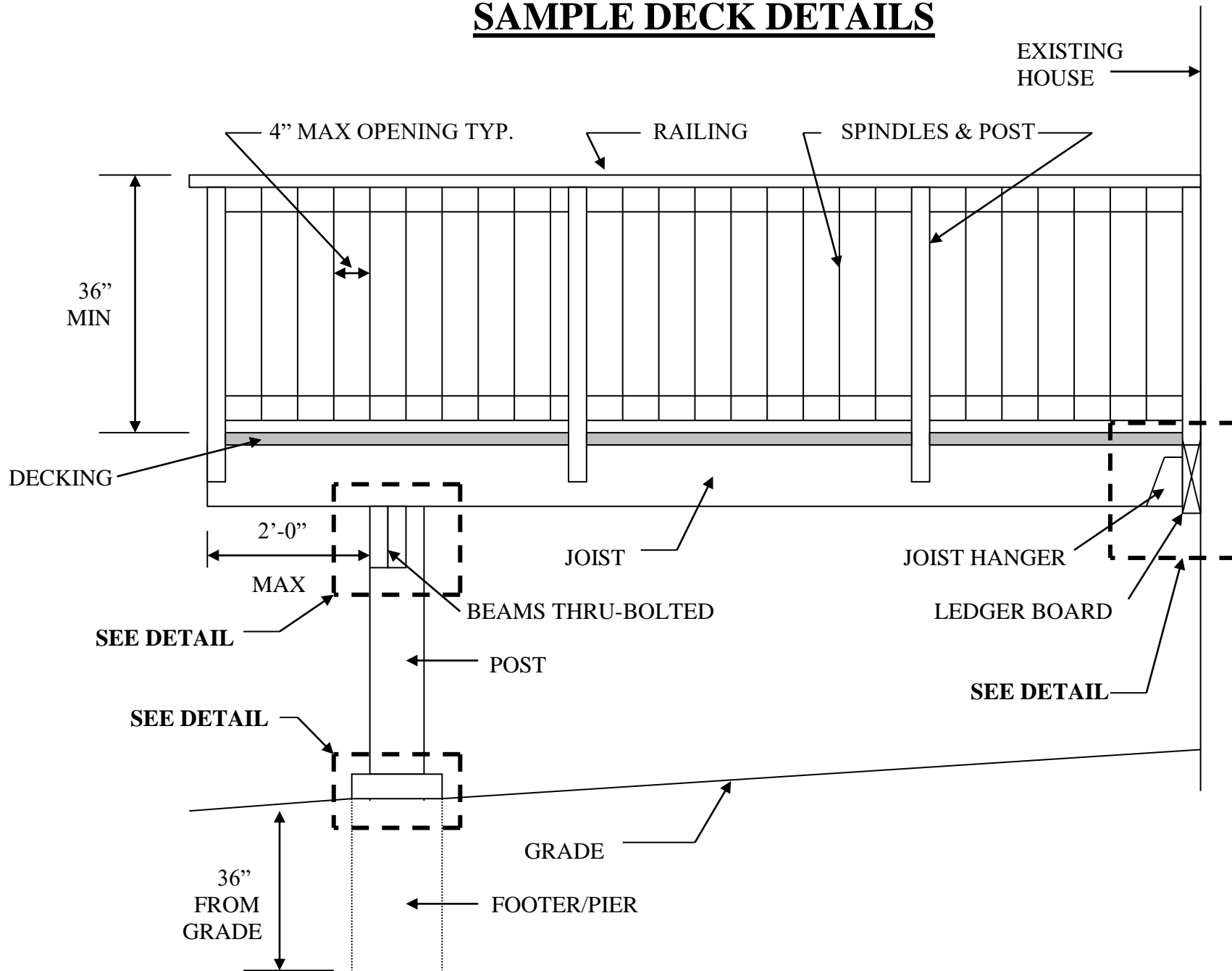

NOTE: THIS DETAIL DRAWING IS A **SAMPLE** ONLY. IT IS TO HELP IN SUMITTING YOUR DESIGN DETAILS AND THE INFORMATION THAT IS REQUIRED FOR CODE REVIEW.

RECOMMENDED BEAM, FOOTER TO POST DETAIL

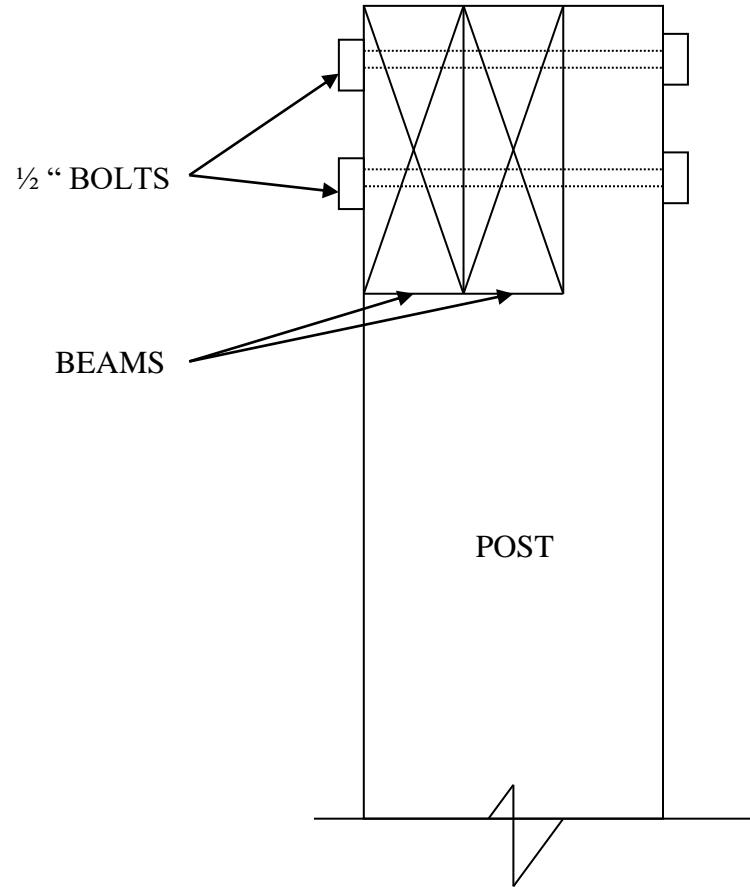
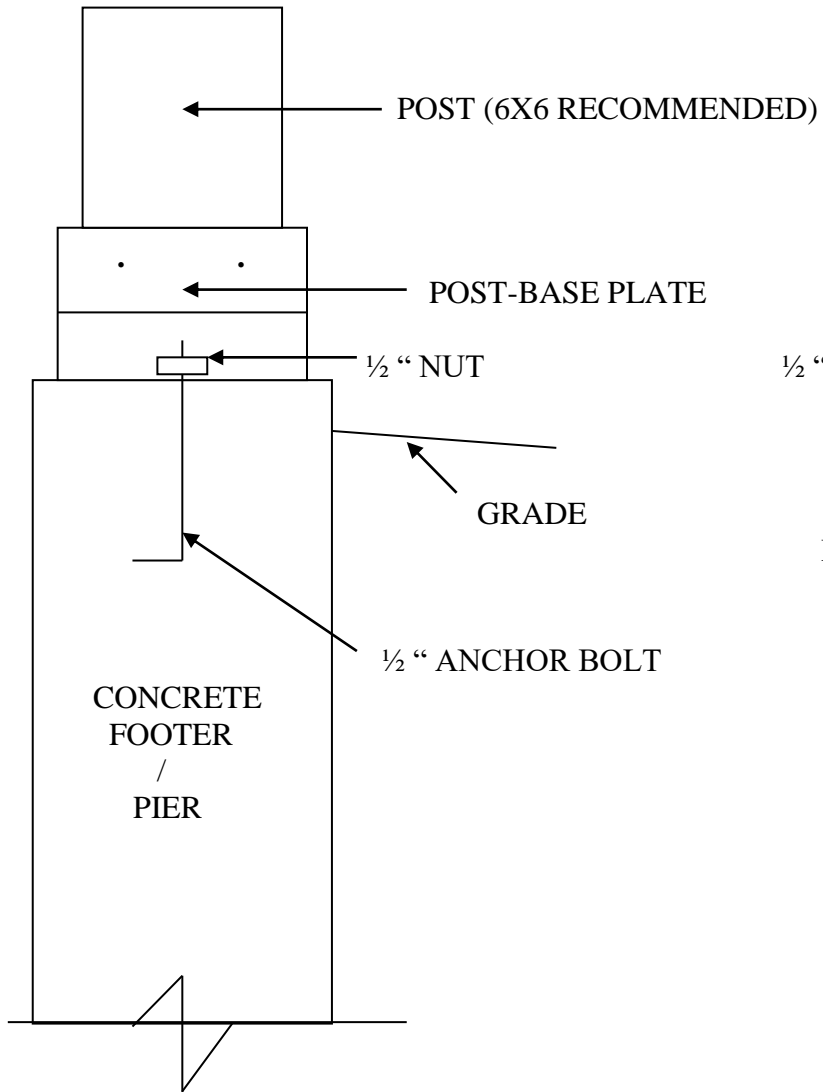

FOOTER/PIER TO POST DETAIL

POST TO BEAM DETAIL

NOTE: THIS DETAIL DRAWING IS A SAMPLE ONLY. IT IS TO HELP IN SUMITTING YOUR DESIGN DETAILS AND THE INFORMATION SHOWN IS REQUIRED FOR CODE REVIEW. EQUIVALENT TOO IN DESIGN WILL BE REVIEWED.

RECOMMENED FLASHING AND LEDGER BOARD DETAIL

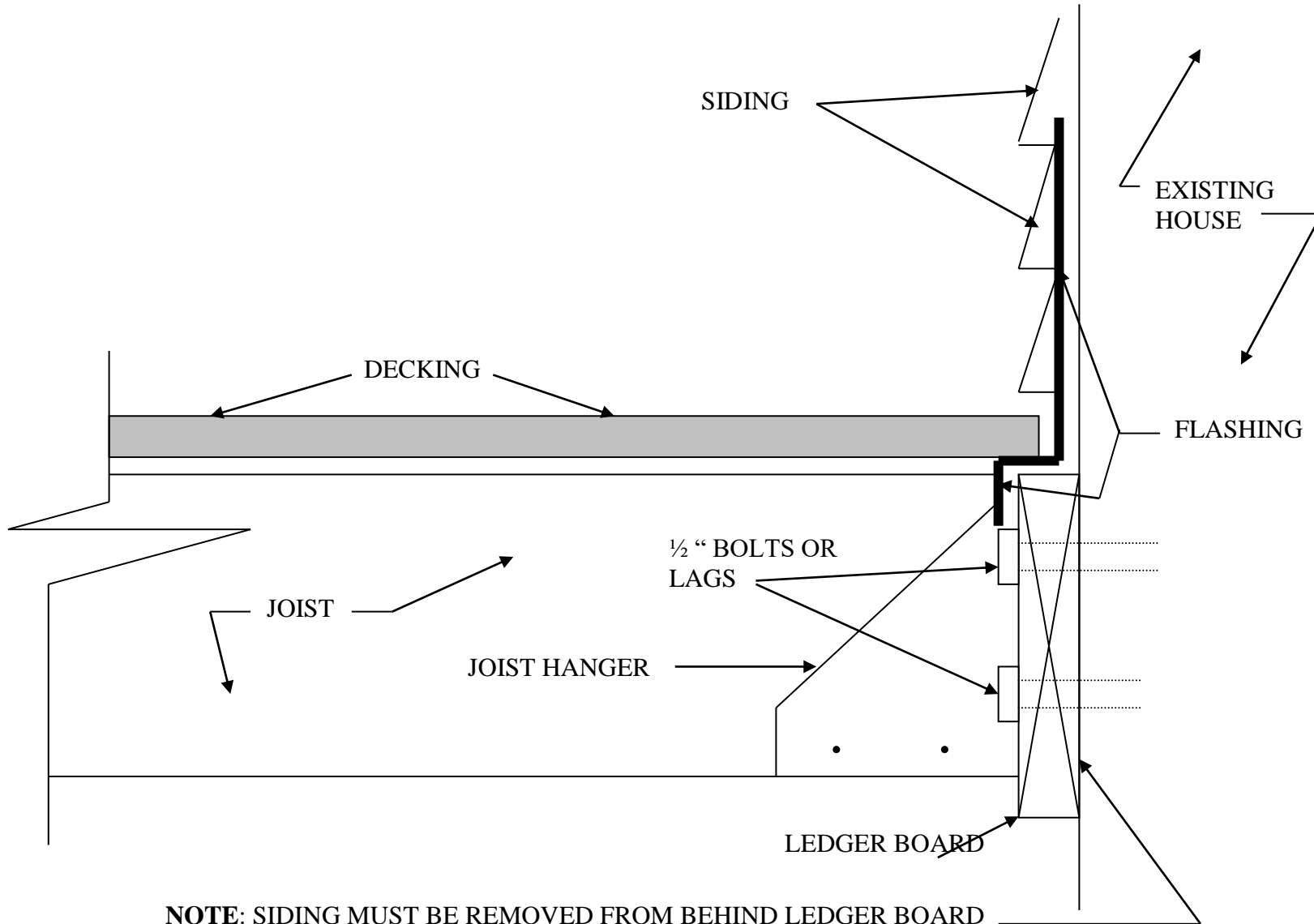

NOTE: SIDING MUST BE REMOVED FROM BEHIND LEDGER BOARD
FLASHING REQUIRED BEHIND LEDGER BOARD

NOTE: THIS DETAIL DRAWING IS A **SAMPLE ONLY**. IT IS TO HELP IN SUMITTING YOUR DESIGN DETAILS AND THE INFORMATION SHOWN IS REQUIRED FOR CODE REVIEW. EQUIVALENT TOO IN DESIGN WILL BE REVIEWED.

DO NOT INCLUDE THIS SHEET - PER TOM

SLAB - SAMPLE DRAWINGS

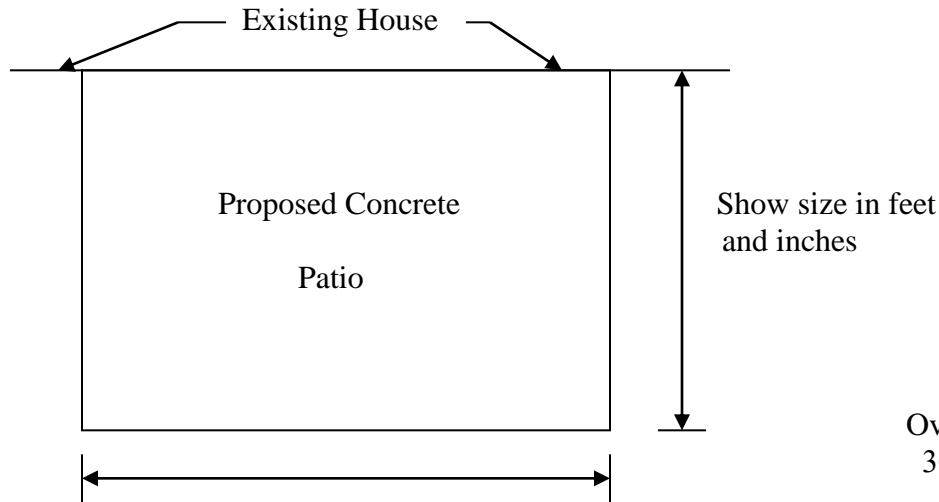

NOTE: THIS DETAILED DRAWING IS A **SAMPLE** ONLY. IT IS TO HELP IN SUMITTING YOU'RE DESIGN DETAILS AND THE INFORMATION THAT IS REQUIRED FOR CODE REVIEW.

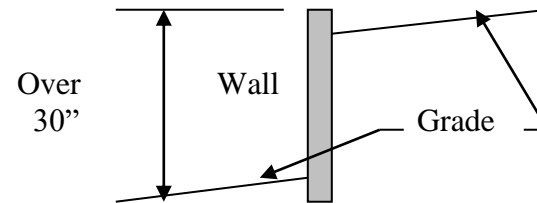

RETAINING WALL

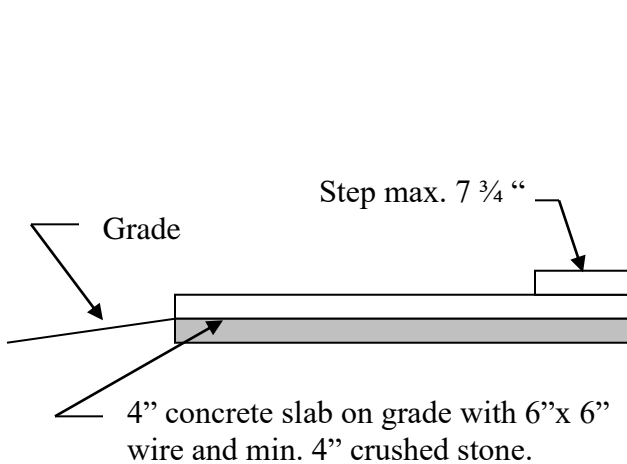

All concrete 3000 PSI

SLAB ON GRADE

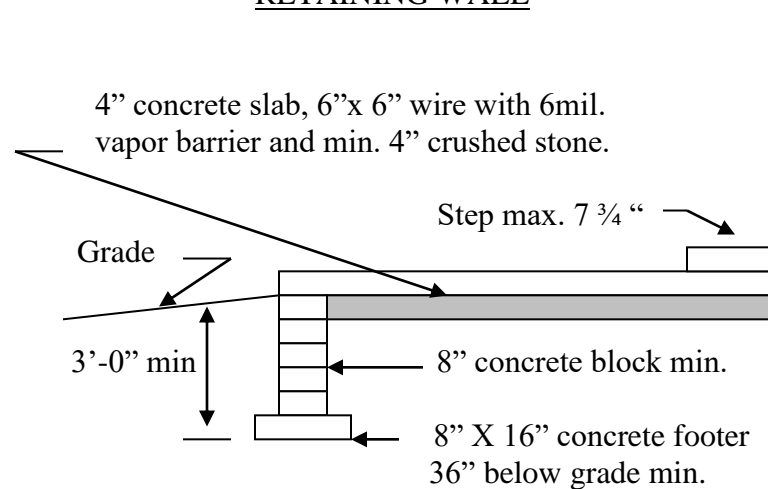

All concrete 3000 PSI

SLAB ON FOOTERS FOR FUTURE ROOM

SAMPLE PLOT PLAN

SHOW ALL SETBACKS, LOCATIONS OF PROPOSED IMPROVEMENTS
AND ALL PHYSICAL CHARACTERISTICS OF PROPERTY

